

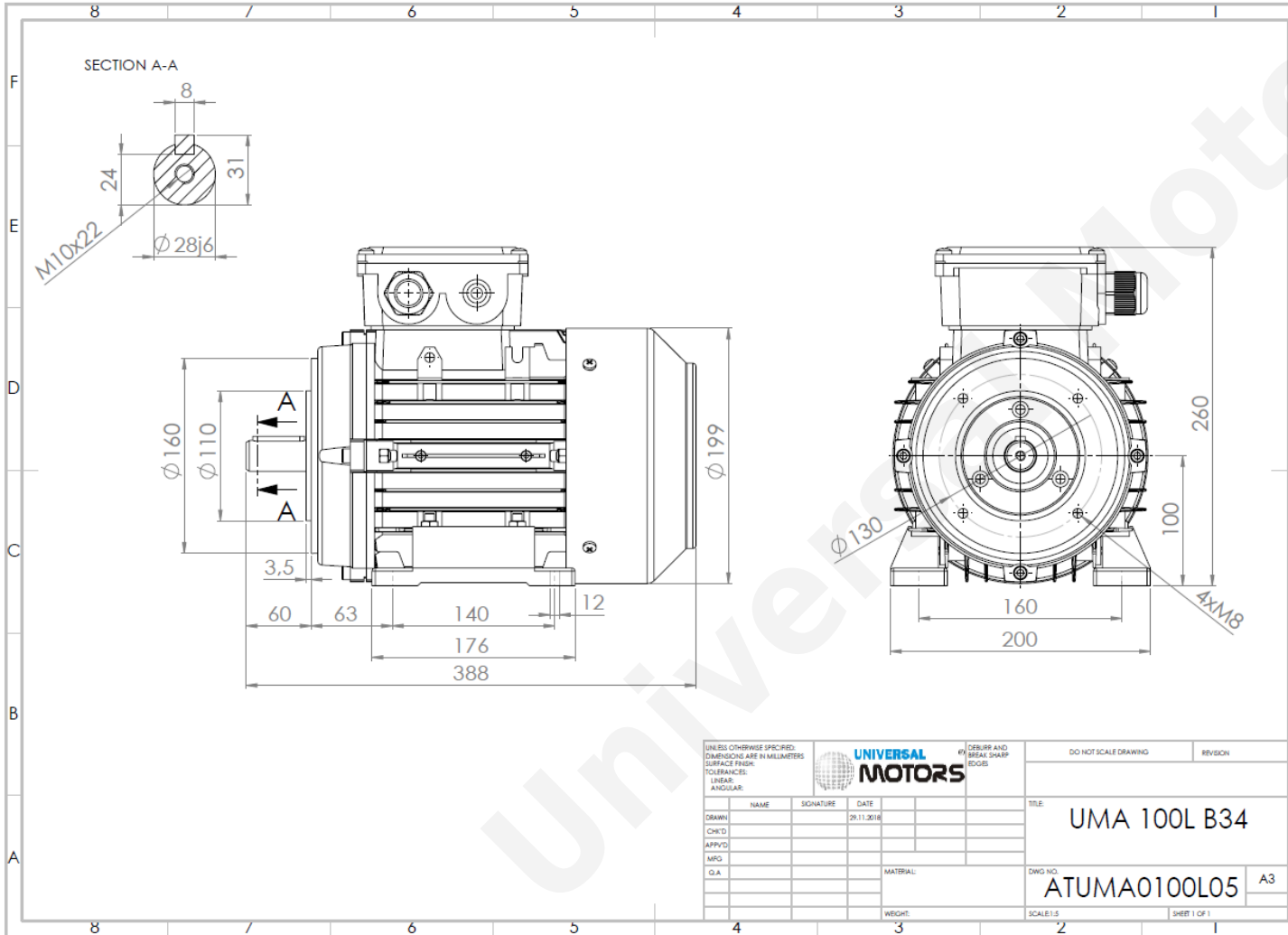

TECHNICAL DATA

Three Phase Electric Motors - Aluminum Frame
 UM2A 100L1-2
 3 kW / 4 Cv
 2890 RPM



Motor type:	UM2A 100L1-2
Output:	3 kW / 4 Cv
Speed (min ⁻¹):	2890 RPM
Frequency:	50 Hz
Voltage:	400 V
Current:	6.09 A
Power factor (Cos Ø):	0.84
Poles:	2
Insulation class:	F
Temperature rise Class:	B
Efficiency 50%:	83.2 %
Efficiency 75%:	84.9 %
Efficiency 100%:	84.6 %
Torque:	10 N.m
Tstarting/Tnominal:	3.0
Istarting/Inominal:	7.6
Tmaximum/Tnominal:	3.6
Noise:	76 Db(A)
Weight:	21.7 Kg
Brake AC:	AC5
Torque Brake DC:	32 N.m
Bearing DE:	6206 2Z
Bearing NDE:	6206 2Z
Torque Brake AC:	40 N.m
Brake DC:	REB-05-12

Regime - S1

Altitude - 1000m

Environment Temperature - 40°C

CONTACTS:

UNIVERSAL MOTORS Tel: +351 252 299 080
 Rua de São Brás,745 Fax: +351 252 299 089
 4480-782 VILA DO CONDE Mail: geral@universalmotors.pt

* References applied only in the UK